

# Aisafer Intelligent Vehicle Terminal

## PG6 Product Manual

**Product model: PG6**  
**Version number: V1.0**

### Copyright Notice

This document is provided by Aisafer, Due to product version upgrades, the document content will be updated from time to time. This document is only used as a guide for users, and all interpretation and modification rights belong to Aisafer. No individual or unit may copy, extract, plagiarize or disseminate the content of this document in any way without the written permission of this company.



## 1. Product Introduction

### 1.1 Product description

PG6 is a new standard intelligent vehicle terminal with an 8-channel camera. This device has 1.5T NPU computing power and can simultaneously support multiple algorithms such as ADAS, DMS, BSD, etc. Its biggest feature is its disaster recovery design, which can ensure that important data is not damaged by external damage. Its multi-functional design can meet the different usage scenarios of users, such as tank trucks, buses, school buses, and various engineering vehicles.

### 1.2 Features

- Support 4G/3G/2G network;
- Support BD/GPS dual-mode positioning (support optional single Beidou positioning);
- Support the new national standard GB/T 19056-2021 version ;
- Supports disaster recovery box (storage capacity 32G), which is expandable ;

- Support 1-channel AHD signal high-definition video output;
- Support 1 SD card/single card 256G storage;
- Support 1 SATA interface mechanical hard disk/solid state hard disk (maximum 2T);
- Supports 8-channel 1080P/720P AHD cameras and supports expansion of 2-channel IPC cameras;
- Support IO signal RS485/RS232/USB/CAN bus/Ethernet and other interfaces;
- 9~36V vehicle voltage input, with circuit protection such as brownout/short circuit/reverse connection;
- Support ADAS automatic calibration, remote real-time video/recording playback, real-time fault tracking, remote parameter query setting, etc.;
- Configurable: one-touch alarm, voice intercom, forward and reverse, fuel consumption, tire pressure, load, temperature and humidity, lift, LED screen and other sensors;

## 1.3 Function Introduction

### 1.3.1 Basic functions of national and ministerial standards

Serial number	function name	Serial number	function name
01	BD/GPS dual-mode positioning	02	4G full network communication
03	Overspeed alarm	04	Fatigue alarm
05	Undervoltage alarm	06	Voice calls
07	Fuel and electricity failure alarm	08	Vehicle trajectories
09	error alarm	10	electric fence
11	One-button alarm	12	Oil volume and other peripherals
13	TTS voice broadcast	14	Driving recorder
15	.....	16	

### 1.3.2 Basic functions of video surveillance

Serial number	function name	Serial number	function name
01	Live Video	02	Video Storage
03	Video playback	04	Video Download
05	Voice intercom	06	Blind spot guide
07	.....	08	

### 1.3.3 AI intelligent algorithm basic functions

Serial number	function name	Alarm rules
Advanced Driver Assistance System--ADAS (standard)		
01	Forward collision detection	The default startup speed is 30km/h, the relative distance/relative speed detection time is 3.0s , the interval is 15s, the graded speed is 50km/h, and the voice: Please pay attention to the car ahead
02	Lane Departure Detection	Default start speed 30km/h, interval 15s, graded speed 50km/h, voice: lane departure
03	Too close detection	Default startup speed 30km / h, relative distance/vehicle speed detection time 1.0s , interval 15s , graded speed 50km/h, voice: pay attention to the distance between vehicles
04	Front pedestrian detection	Default startup speed 1-50km/h, interval 15s, all level 2, voice: Watch out for pedestrians
Fatigue driving warning system--DSM (standard)		
01	Smoking detection	The default startup speed is 30km/h, the detection time is 5-30s, the interval is 20s, the graded speed is 50km/h, and the voice: Do not smoke
02	Distraction Detection	The default startup speed is 30km/h, the detection time is 3s, the interval is 30s, the graded speed is 50km/h, and the voice: Please concentrate on driving
03	Eye closure detection	The default startup speed is 30km/h, the detection time is 3s, the interval is 10s, the graded speed is 50km/h, and the voice message is: Do not drive while tired
04	Yawn detection	The default startup speed is 30km/h, the detection time is 1s, the interval is 10s, the graded speed is 50km/h, and the voice message is: Do not drive while tired
05	Phone test	The default startup speed is 30km/h, the detection time is 10s, the interval is 20s, the graded speed is 50km/h, and the voice: Do not make calls
06	Driver	Default start speed 30km/h, detection time 20s, interval 15

	abnormality	minutes, graded speed 50km/h, voice: driver not detected
07	Sunglasses failure detection	Default startup speed 30km/h, detection time 3s, interval 10s, graded speed 50km/h, voice: Sunglasses are invalid
08	Identity detection	Default level 2, with alarm and evidence, voice: driver identification successful/illegal driver
09	.....	
Blind Spot Detection Warning System--BSD (optional)		
01	Front blind pedestrian detection	Default startup speed 0-30km/h, interval 15s, all level 1, voice: Danger, please pay attention
02	Right-hand blind pedestrian detection	Default startup speed 0-50km/h, interval 15s, all level 1, voice: Danger, please pay attention
03	.....	

### 1.3.4 AI Intelligent Algorithm Function Overview

#### ■ Advanced Driver Assistance System (ADAS)

Is an active safety technology that uses AI algorithms for intelligent image analysis. It can identify, detect and track static and dynamic objects, allowing drivers to detect potential dangers in the shortest possible time and prevent traffic accidents. Its main functions are:

##### ➤ FCW forward collision warning

Utilizes the visual intelligent vehicle-mounted sensor to monitor the vehicle ahead in real time, and determines the distance, relative speed and direction between the vehicle and the vehicle ahead. When the system determines that there is a potential danger, it will warn the driver and remind the driver to brake to ensure driving safety .

##### ➤ HMW vehicle distance monitoring and warning

By sensing and calculating the distance and absolute speed between the vehicle and the vehicle in front during driving, the real-time vehicle distance time between the vehicle and the vehicle in front is monitored in real time. When the vehicle distance time is less than the alarm time set by the system, a warning alarm is immediately issued to remind the driver to pay attention to the distance between the following vehicles and avoid rear-end collision.

##### ➤ LDW Lane Departure Warning

Utilizes visual intelligent vehicle-mounted sensors to monitor the lane ahead in real time . When the driver deviates from the original lane unconsciously (without turning on the turn signal), an alarm is issued in advance to remind the driver of the current vehicle deviation, providing the driver with more reaction time and greatly reducing collision accidents caused by lane departure.

### ➤ **PCW Pedestrian Collision Warning**

Use visual intelligent vehicle-mounted sensors to monitor pedestrians, cyclists and other targets in front of the vehicle in real time, select key pedestrian targets, make comprehensive decisions based on vehicle speed and target distance information, and send alarm information to the driver to avoid pedestrian collision accidents.

### ■ **driver fatigue warning system DSM**

Is an active safety technology that uses AI algorithms for intelligent image analysis. It detects the driver's driving behavior and physiological state through visual tracking, target detection, action recognition and other technologies. When the driver is in dangerous situations such as fatigue, distraction, making phone calls, smoking, etc., the system will alarm within the set time to avoid accidents. Its main functions are:

#### ➤ **Fatigue driving detection**

By analyzing the driver's fatigue characteristics (such as yawning, closing eyes, etc.), fatigue driving warnings are issued in time for fatigue behaviors. The highly accurate algorithm can even effectively manage the driver's fatigue state regardless of external conditions such as time period, lighting conditions, and whether the driver is wearing sunglasses. When the driver is in a state of physiological fatigue, an early warning warning is issued immediately to wake the driver up in time to avoid serious accidents.

#### ➤ **Smoking monitoring**

When the driver smokes while driving, the DSM system will accurately and timely capture the driver's smoking behavior and issue a timely warning to the driver to avoid safety accidents caused by smoking while driving.

#### ➤ **Phone call monitoring**

When the driver makes phone calls while driving, the DSM system will accurately and timely capture the driver's phone calls and issue a warning to the driver in time to avoid safety accidents caused by phone calls while driving.

#### ➤ **Distracted Driving Monitoring**

When the driver takes his eyes off the road while driving (including looking around for a long time without turning on the turn signal, or looking down at his phone), the DSM system will accurately and timely capture the driver's distracted driving behavior and issue a timely warning to the driver to avoid safety accidents caused by the driver's distraction during driving.

#### ➤ **Abnormal status monitoring**

When the driver changes drivers, leaves the normal driving position, blocks or damages the DSM camera during driving, the DSM system will accurately and timely capture the driver's abnormal behavior and issue a timely warning to remind the driver to drive safely.

## 1.4 Interface Description

### ■ Front panel interface

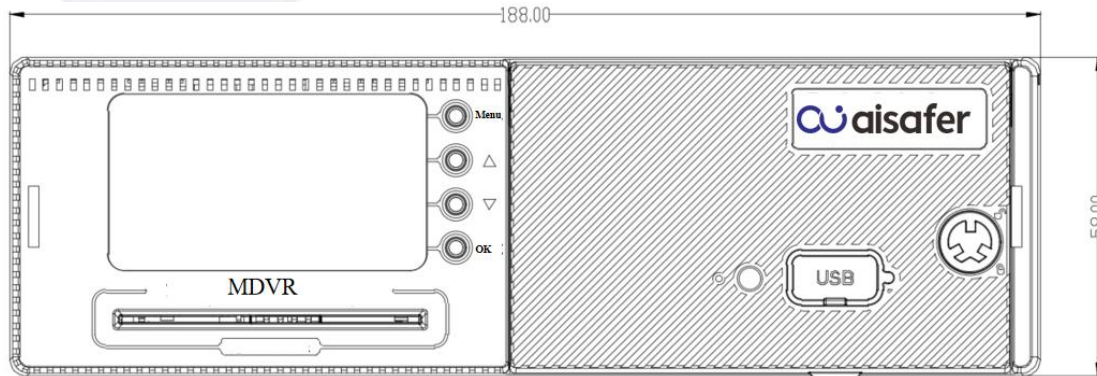

category	Logo	describe
instruct	IR	Remote control IR infrared receiver
	LCD screen	Display device system information
Card slot	SIM	SIM card slot ( <b>medium card</b> )
	SD	SD card slot
	harddisk	Mechanical hard disk/solid state drive installation slot
	IC Card	Driver IC card installation slot
button	menu	Button Menu Options
	Up key	Button scroll up options
	Down key	Press button to scroll down options
	confirm	Press key to confirm option
interface	USB	Export/Import Device Data Interface
Device Lock	Lock	Storage media cover lock

### ■ Rear panel connector

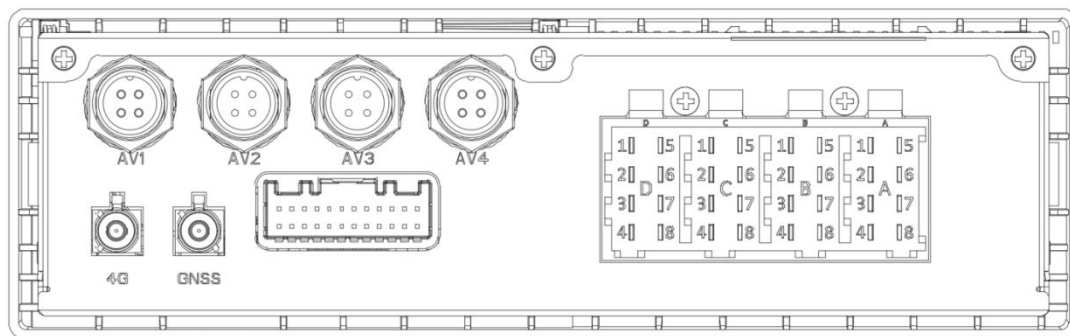

category	Logo	describe
power supply	POWER/RS485/RS232/IO	Power line interface/RS485/RS232/IO/CAN communication interface
position	GNSS	GNSS positioning antenna interface
network	4G	4G network antenna interface
Video port	AV5-AV8/AHD/MIC/speaker/network port	Camera/Video Output/MIC/Speaker/Network Interface
Camera	AV1-AV4	Camera interface x4

■ Interface definition

category	Logo	describe
Power cord interface	POWER/485/232/IO	32PIN socket: device power supply and IO/485/232/CAN communication interface
Camera port	AV1/AV2/AV3/AV4	4PIN aviation header x4
Video port	AV5-AV8/AHD/MIC/speaker/network port	24PIN plug to Camera input: 4PIN aviation connector x4 AHD output: 4PIN aviation connector x1 MIC IN: 2PIN plug x1 Speaker: 2PIN plug x1 Network interface: 6PIN aviation connector x1

■ Power line interface definition

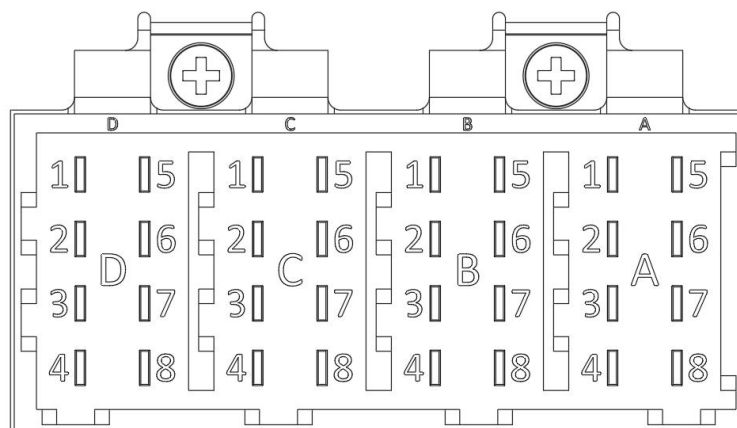



A	definition	B	definition	C	definition	D	definition
1	Power+ Power-IN+	1	RS485-VCC 12V-OUT	1	RS232-MCU-RX	1	Turn left
2	ACC-IN	2	CAN2-L/RS485B	2	RS232-MCU-TX	2	Turn right
3	Power + (reserved)	3	Speed input SPEED-IN	3	GND	3	High beam
4	CAN1-H	4	CAN2/RS485-GND	4	RS232-DEBUG-RX	4	Low beam lights
5	Power-IN-	5	Brake-IN4	5	RS232-DEBUG-TX	5	Rear fog lamps
6	Power supply - (reserved)	6	CAN2-H/RS485A	6	Speed output SPEED-OUT	6	Reversing
7	CAN1-GND	7	Hijacking a Police Officer-SOS	7	ADC1	7	seat belt
8	CAN1-L	8	Self-test output	8	ADC2	8	Car door

■ (2) Camera port definition

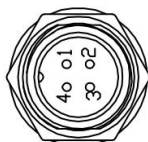

1	Power supply 12V	3	audio signal
2	GND	4	Video signal

■ (3) Video port definition

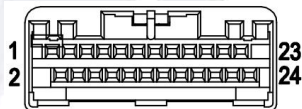

1	AHD-CH5	9	12V-OUT	17	External MIC+
2	AIN5	10	12V-OUT	18	External MIC-
3	AHD-CH6	11	12V-OUT	19	External speaker+
4	AIN6	12	Display screen power supply 12V-Dispaly	20	External speakers -
5	AHD-CH7	13	Display video output AHD-OUT	twenty one	Ethernet ETH-TX+
6	AIN7	14	GND	twenty two	Ethernet ETH-TX-
7	AHD-CH8	15	GND	twenty three	Ethernet ETH-RX+
8	AIN8	16	GND	twenty four	Ethernet ETH-RX-

## 1.5 Technical Parameters

Product Specifications		
system	operating system	Embedded Linux operating system
	Operating language	Chinese
	User Interface	Graphical menu operation interface
	Password security	Two-level management of user password and administrator password
Audio and Video	Video format	PAL/NTSC
	Compression Standard	H.264 /H.265
	Image Resolution	1080P/ 720P/D1/ HD1 /CIF
	Video quality	1 to 8 levels are available , 1 is the highest quality, 8 is the lowest
	Screen Display	Support 1, 4 , 8 screen display
	Audio Compression	G711A , G726-32K , G726-40K
	Recording method	Synchronous recording of audio and video
Video	Video bitrate	Full frame rate 8Mbps , 8 levels of image quality optional
	Audio Bitrate	8KB/s
	Storage Media	SD card /mechanical hard disk/solid state drive storage
	Video Query	Can search by channel and video type
	Local playback	Playback by file
interface	Audio and video input	8-channel 1080P/720P aviation head AHD audio and video camera
		2-channel 720P aviation head IPC audio and video camera
	Video Output	1 channel AHD video output
	Alarm input /output	8 input signals/2 output signals
	Communication Interface	1 RS485 , 1 RS232 , 2 CAN buses , 1 USB 2.0
	Antenna interface	1 GNSS positioning antenna
		1 4G full network communication antenna
	Intercom interface	1 external speaker/ 1 intercom MIC interface
	Bluetooth	support
	Display	Display
	SIM card	1 large card
	harddisk	1 mechanical/SSD, up to 2T storage, 7mm/9mm optional
	SD Card	1 SD card , single card up to 256G
Device Lock	Device power on/storage media baffle lock 1	

other	power input	DC: 9V~36V
	Power Output	12V / 1A
	Power consumption	4-way camera: 17W (standard), 8-way camera: 25W (standard)
	Operating temperature	-30 ~ 70 °C
	storage	D1 About 500M /hour/channel , 720P About 1G/hour/channel , 1080P about 2G/hour/channel
	Disaster recovery box	Storage capacity 32GB
software upgrade	Upgrade Mode	Manual upgrade, automatic upgrade, remote upgrade
	Upgrade Method	USB port, SD card, wireless network

## 2. Structure Diagram

### 2.1. Structural explosion diagram

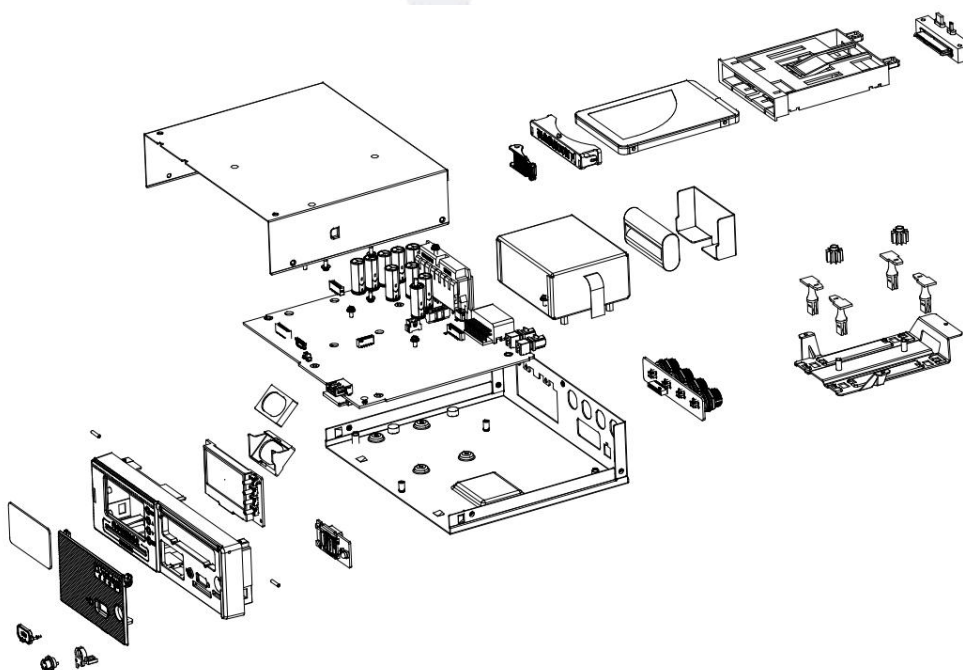

### 2.2. Product Dimensions

name	size
PG6 host	188mm * 172mm * 58mm(L*W*H)

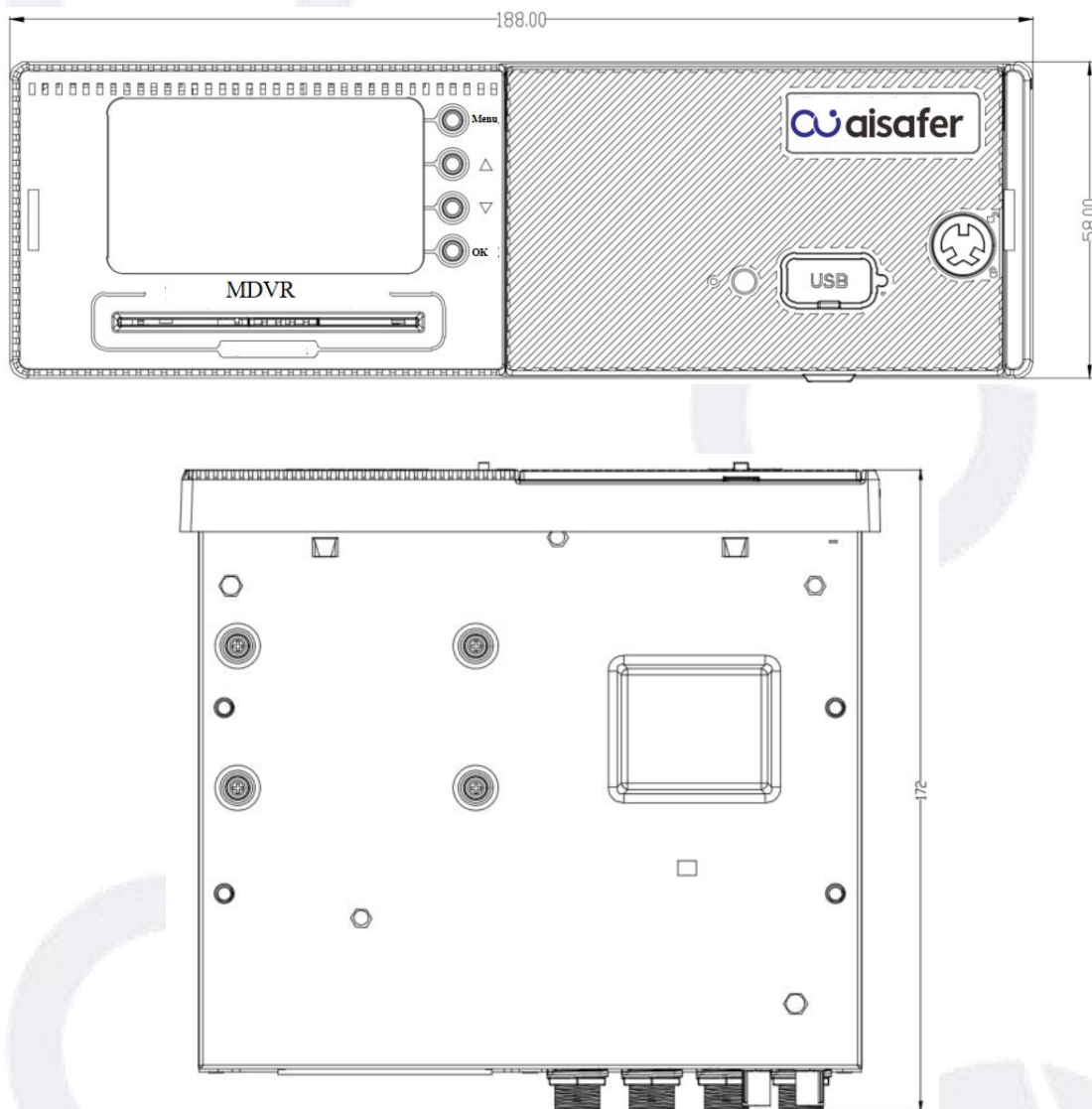

### 3.1. Product Overview

PG6 ADAS camera is a high-resolution, low-power AHD video signal in-vehicle camera product with a plastic shell and unique appearance. Fully automatic electronic shutter and automatic exposure effectively ensure the image effect of light/dark environment changes, fast imaging response speed, and low-illumination chip to ensure good image effect in dark environment.

The chip used is a CMOS image sensor, which is used in various vehicle-mounted and security equipment. It has a high-definition 1080P (FHD) camera function at 30fps, a 1920x1080 pixel sensor array chip, programmable gain control (PGA) and double sampling (CDS), which can significantly reduce fixed pattern noise (FPN).

The structure can adjust the viewing angle up and down, and adopts 4P micro aviation plug

interface, which makes the contact more reliable and firmer. The structure is simple and beautiful, and the installation is convenient. It is suitable for various vehicle installations.

### 3. PG6 ADAS Camera

#### 3.2. Technical parameters

PG6 ADAS camera specifications	
size	100 X 71 X 40 MM
Pixel	1920H×1080V
Output Format	AHD
Mirror function	Pre-image
Maximum frame rate	25 fps
Audio output	not support
Operating Voltage	DC 12V
Operating temperature	-20°C ~ 70°C

#### 3.3. Structure diagram

Structure size:

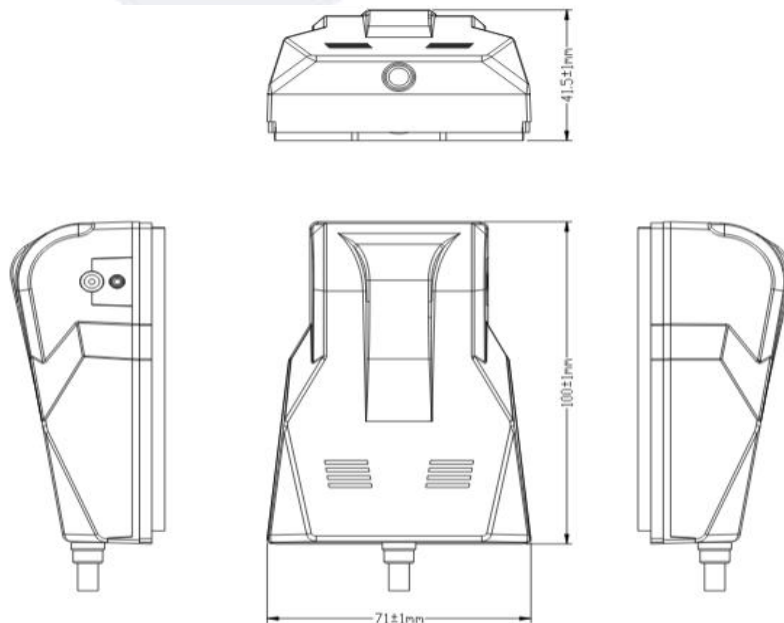

## 4. PG6 DSM Camera

### 4.1. Product Overview

PG6 DSM camera is a recognition camera product that uses pure 940nm non-red burst infrared fill light, high resolution, low power consumption AHD video signal. Automatic exposure control effectively ensures the image effect of light/dark environment changes. Low illumination chip ensures good image effect in dark environment.

It uses CMOS image sensors and is used in various vehicle-mounted and security equipment. It has a 30fps high-definition 720P (FHD) camera function and a 1920x1080 pixel sensor array chip. The structure can adjust the viewing angle up and down.

### 4.2. Technical parameters

PG6 DSM camera specifications	
size	114 * 65 * 28 MM
Pixel	1280H×720V
Output Format	AHD PAL
Mirror function	Pre-image
Maximum frame rate	25 fps
Audio output	support
Minimum illumination	940 infrared fill light
Operating Voltage	DC 12V
Operating temperature	-20°C ~ 70°C

### 4.3. Structure diagram

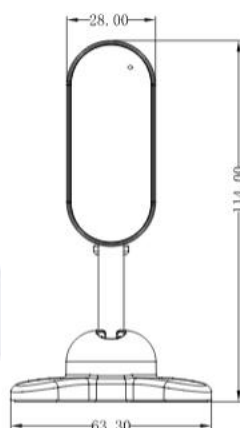

## 5. Operation Instructions

### 5.1. Installation location

Name	Must Require
Host	Lock and fix it in a suitable place such as the central control platform, tighten the screws of the accessory interface, and lock the device cover lock;
ADAS Camera	Below the front windshield, in the middle of the horizontal direction, the image angle is half sky and half ground;
DSM Camera	Directly in front of the steering wheel, about 80cm away from the head, the head must be in the center of the picture, and the steering wheel cannot be in the picture;
GNSS positioning antenna	It should be completely facing up, with separate wiring, and placed flat on a separate area on the center console, away from interference sources on the car, and no accessories should be allowed within 50cm around it;
4G communication antenna	It is completely facing up, with separate wiring, and is flat on a separate area on the center console, away from interference sources in the car;

### 5.2. Installation location diagram:

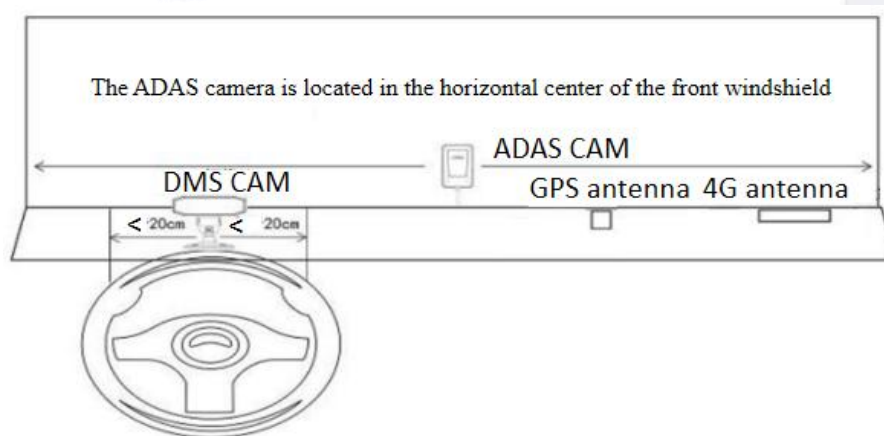

- ADAS algorithm camera screen angle example DSM algorithm camera screen angle example

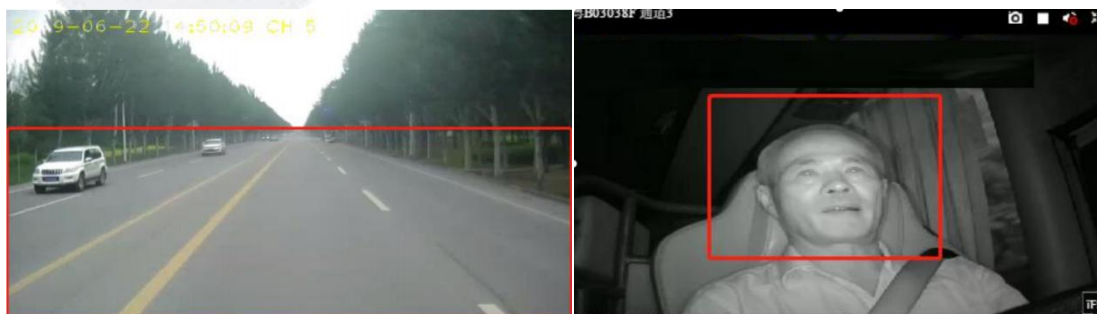

### 5.3. Wiring Instructions

Name	Online tag name	Must Require
power cable	power supply	Choose a thick enough wire and connect it to the positive pole of the normal power supply in the car;
	GND	Choose a thick enough wire and connect it to the ground of the screw on the car or connect it in parallel with the negative pole of the power supply;
	ACC	Connect the ACC signal line on the car (car key control);
Communication interface cable	Turn left	Connect the left turn signal line on the vehicle;
	Turn right	Connect the right turn signal line on the vehicle;
	High beam	Connect the high beam signal line on the vehicle;
	Low beam	Connect the approach light signal line on the vehicle;
	brake	Connect the brake signal line on the vehicle;

### 5.4. Online Parameters

name	Must Require
IP	Required: Set according to the IP number configured for the terminal by the platform, for example: 036.108.254.098;
port	Required: Set according to the port number configured for the terminal by the platform, for example: 7611;
agreement type	Required: Select the corresponding protocol settings according to the platform, for example: Subiao ;
Phone number	Required: Set according to the mobile phone number of the vehicle registered on the platform, for example: 19011321313;
number plate	Required: Set the real license plate number, for example : BP0001;
Terminal ID	Required: Set according to the terminal ID of the vehicle registered



	on the platform, for example: 1321313;
License plate color and other parameters	Optional: Set other parameters such as license plate color according to platform online requirements, for example: blue;

## 5.5. Install and maintain app

step	operate	illustrate
first step	Download the operation and maintenance app	
Step 2	Connect your device to WiFi using your mobile phone	
third step	Setting parameters	[Set parameters] Fill in [License plate number/Terminal mobile phone number/Terminal ID/Main server IP/Port/Protocol]; Backup server can be set as needed

## 6. Frequently Asked Questions

Fault	Cause Analysis	solution
The power indicator light is	The power line, GND and ACC are	Check the power, GND and ACC
	The power cord fuse is blown	Eliminate the short circuit and replace
	Terminal equipment is damaged	Return to the factory for repair
The device is not online	SIM card has no data	Contact your network operator to pay
	Online parameter setting error	Use Zhixing Operation and
	Is the SIM card in good contact?	Reinstall the SIM card
	Communication antenna abnormality	Retighten or replace the
Video cannot be opened	The vehicle is in an underground	Drive away from areas with poor
	SIM card data is limited	Contact your network operator to pay
	ACC Off	Check ACC line
Unable to locate	The vehicle is in an underground	Drive away from areas with poor
	The vehicle is in an underground	Leave the above area
	The positioning antenna is installed	The antenna installation position
	The positioning antenna receiving	Remove obstructions
	Positioning antenna open circuit	Tighten the antenna connector or
	Positioning antenna failure	Replace the positioning antenna
The positioning antenna is intertwined	Try to route the positioning antenna	

## 7. Notes

1. Antenna installation location: When installing, please do not entangle the 4G antenna, positioning antenna, video cable, and power cable together. They must be routed separately.

To reduce interference, the installation distance between the 4G antenna and positioning antenna and the device should be kept at least 50CM, and the antenna cannot be blocked by metal parts.

2. Replace SD card/SIM card: The SD card and SIM card must be completely powered off before plugging in and replacing them.

3. ADAS algorithm camera: The sky and the ground should occupy half of the picture as much as possible, and it should be placed in the middle of the front windshield in the horizontal direction. When installing, use the level gauge in the installation package to ensure a level installation.





4. DSM algorithm camera: When sitting normally while driving, the head portrait should be in the center of the screen as much as possible and installed in the front as much as possible.





5. Wiring: The power cord and GND wire should be as thick as possible (close to the thickness of the device power cord). All wire connections should be securely connected and wrapped with tape.

6. SIM card: The device only supports medium-sized card installation.

7. BSD installation: Connect physical channel AV4 channel .

## 8. Components

Serial number	name	Graphics	quantity
1	PG6 host		1
2	ADAS Camera		1
3	DSM Camera		1
4	power cable		1

5	Video cable		1
6	4G Antenna		1
7	GNSS Antenna		1
8	Driver IC card		2
9	Installation materials		1